



Instructions of use



Table of contents

1. Field of application	2
2. Model	2
3. Inserting / Exchanging batteries.....	2
3.1 Initial operation.....	3
4. General operation	3
4.1 Unlocking the keyboard.....	3
5. User menu.....	4
5.1 Leakage protection.....	4
5.2 Setting the leakage protection.....	4
5.3 Deactivating the leak. protection.....	5
5.4 Vacation leakage protection	5
5.5 Setting the vacation leakage protection.....	6
5.6 Deactivating the vacation leakage protection	6
5.7 Stop valve	7
5.8 Changing the stop valve's status	7
5.9 Re-opening the stop valve after leakage.....	7
6. Other settings.....	8
6.1 48h-leakage	8
6.2 Changing the 48h-leakage mode	8
6.3 Time-based leakage (volume).....	8
6.4 Time-based leakage (flow rate).....	9
6.5 Unlocking the device	9
6.6 External alarm contact	9
6.7 Buzzer	10
6.8 Contact 1	10
6.9 Contact 2	10
6.10 Mounting conditions	11
7. System information	11
7.1 Serial number.....	11
7.2 Battery power.....	11
7.3 Alarm memory.....	12
8. Emergency unlock function	12
8.1 Restart.....	13
9. Technical specifications.....	14
10. Connections	14
11. Accessories	14
12. Dimensions	15
13. Messages.....	16

1. Field of application

The SYR-Safe-T is an effective anti-leakage system in compliance with recognized international standards. It is adaptable to all SYR flanges from DN 20 to DN 32.

2. Model

Fully automatic electronic anti-leakage system with contacts for many different connection possibilities.

With two O-rings, a seal, small hexagonal socket screws for the installation, a mounting key and a floor sensor.

3. Inserting / Exchanging batteries

Warning: The batteries have to be inserted even when using the mains plug!

Insert the batteries prior to using the Safe-T.

Open the upper battery door and remove the battery block.

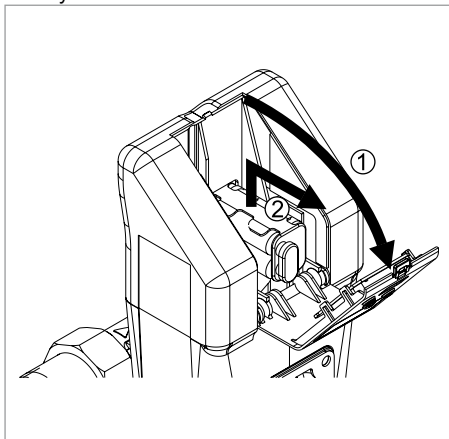

Insert the battery block or exchange it (4 x LR 06) and put it back into place in the battery compartment.

Make sure that the battery block is correctly positioned in the compartment against the internal back wall.

Close the battery door.

As an option, you can also connect the SYR Safe-T with a mains plug (1100.00.900).

Exchange the batteries every two years at the latest!

Do not use accumulators!

3.1 Initial operation

As soon as the batteries are inserted, the system first goes into the closed position.

The display shows the message IO.

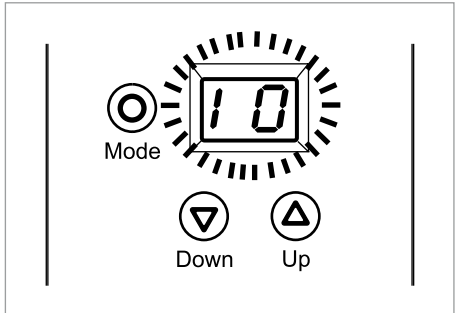

When pressing the - key, the system goes into the open position.

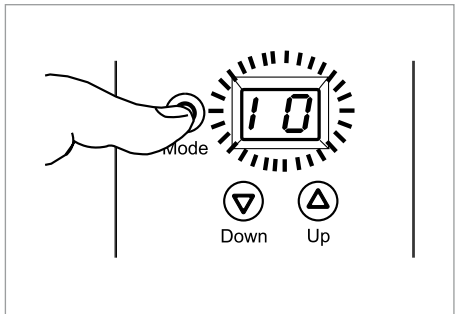

The system is open when the message 10 flashes in the display. Afterwards, it goes into the normal operation mode.

4. General operation

The display consists of two digits and three press buttons (mode, down and up key).

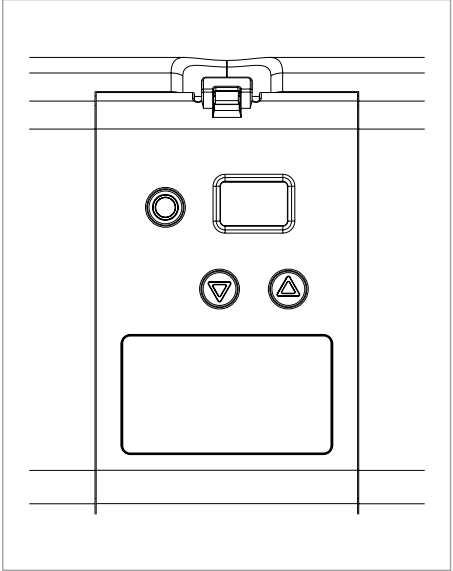

Use the or key to adjust the various values.

Use the key to confirm and save the values or to activate another menu.

Symbol	Key	Meaning
	Mode	To validate entries
	Down	To decrease values
	Up	To increase values

4.1 Unlocking the keyboard

When the Safe-T is exclusively battery-operated, press any key to activate the display. It will automatically disconnect after 30 seconds.

The device's keyboard is locked.

Unlock the keyboard to change values.

Press simultaneously the \odot and \triangle key for about 3 seconds. The display starts flashing to signal that the keyboard is unlocked.

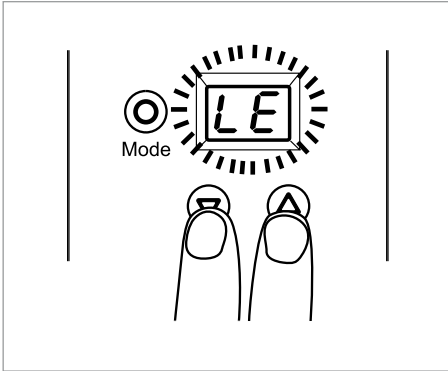

When no key is activated within 30 seconds, the display goes back into the locked position.

When the device is mains-operated, the display always remains active.

5. User menu

5.1 Leakage protection

The leakage mode provides for a standard supervision of the installation.

The system calculates the volume flow without interruption as well as the flow rate.

Should one of the following criteria be exceeded, the device suspects a leakage problem and closes the main isolating valve.

- In case the water quantity flown without interruption exceeds the set limit for the volume-based leakage (100 - 1500 liters) → Message A3 is displayed.
- In case the flow rate exceeds 3500l/h for one minute → Message A4 is displayed.
- In case of an uninterrupted flow of water

during 2 hours with a setting of 100 to 400 liters → Message A9 is displayed.

- In case of an uninterrupted flow of water during 3 hours with a setting of 500 to 700 liters → Message A9 is displayed.
- In case of an uninterrupted flow of water during 4 hours with a setting of 800 to 1100 liters → Message A9 is displayed.
- In case of an uninterrupted flow of water during 5 hours with a setting of 1200 to 1500 liters → Message A9 is displayed.

5.2 Setting the leakage protection

When pressing the \odot key, the menu for the vacation leakage protection appears in the display, provided it is activated.

When pressing the \odot key again, the current anti-leakage setting is displayed.

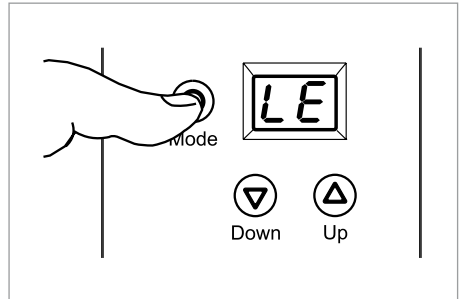

Unlock the keyboard, if needed.

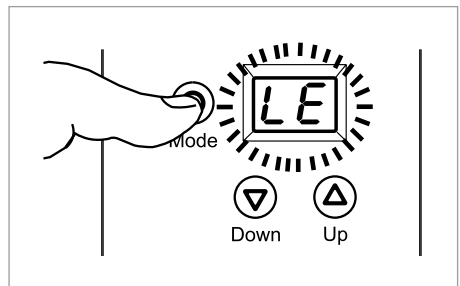

The message „LE“ flashes in the display.

When pressing the \odot key again, the menu for the leakage protection displayed.

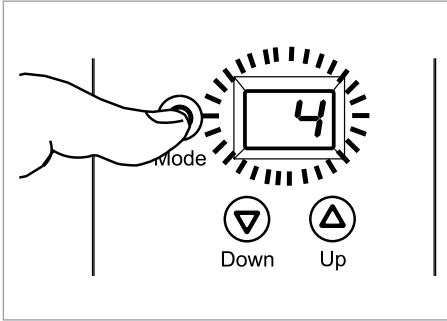

Press the  key to display the current setting.



Set the desired value by means of the  - or  key.

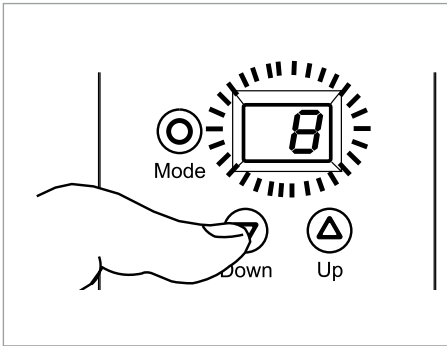

The system allows for the following settings:



Menu	Values
Leakage protection (LE)	-- (deactivated) 1 - 15 (100 - 1500 liters) (Factory set to: 4)
Vacation leakage protection (UL)	-- (deactivated) 1 - 10 (10 - 100 liters) Factory set to: 10
Stop valve (AB)	P1 (OPEN), P2 (CLOSED) Factory setting: P1 (OPEN)

Press the  key to validate and save the changes.

5.3 Deactivating the leakage protection

To deactivate the leakage protection, unlock the keyboard, if necessary.

Press the  key until reaching the menu „LE“.

Set the desired value by means of the  or  key.

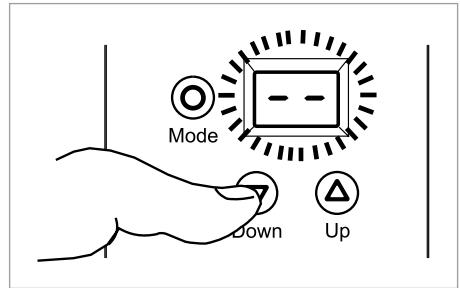

Press the  key to save the settings.

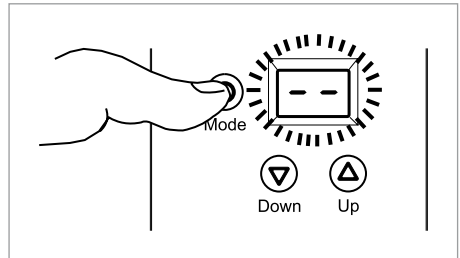

Note: The leakage protection system is automatically reactivated after 8 hours!

5.4 Vacation leakage protection

Should a tighter supervision be needed for a certain time, use the vacation leakage protection mode.

This setting implies that only minor water quantities between 10 and 100 liters will be drawn off without interruption.

When the indicated water quantity is exceeded, a leakage problem is suspected → Message A5 is displayed.

Press the **Mode** key until the vacation leakage protection is displayed.

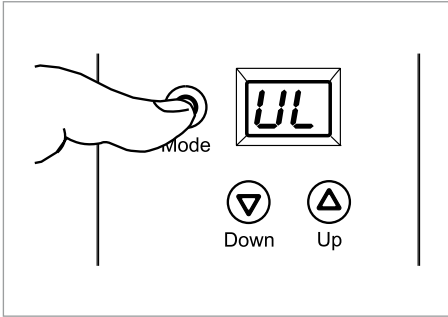

Set the desired value by means of the **Down** or **Up** key.

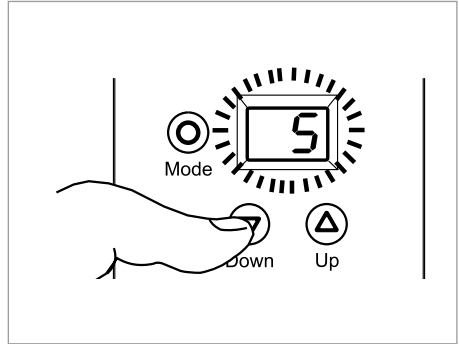

Press the **Mode** key again to display the current setting of the vacation leakage protection.

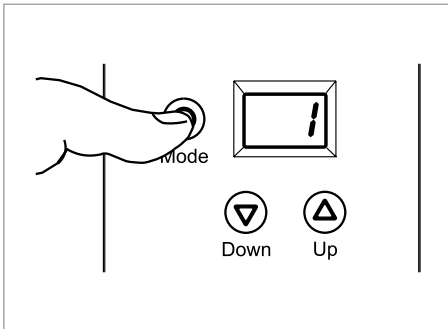

Press the **Mode** key to save the settings.

5.6 Deactivating the vacation leakage protection

In order to deactivate the leakage protection, set the desired value by means of the **Down** or **Up** key.

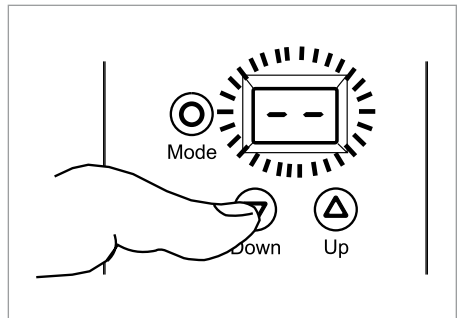

5.5 Setting the vacation leakage protection

In order to change the setting of the vacation leakage protection, unlock the keyboard, if necessary.

Press the **Mode** key until reaching the „UL“ menu.

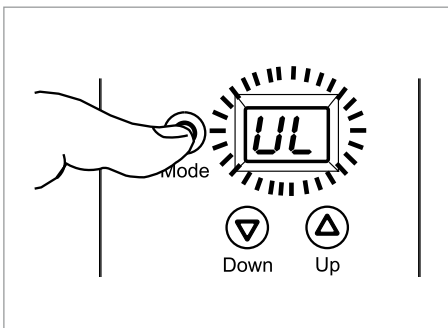

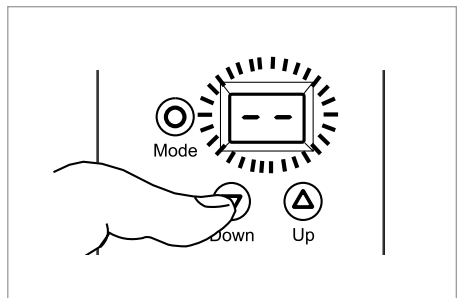

Press the **Mode** key to save the settings.



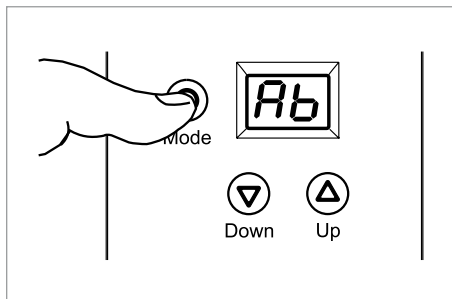

5.7 Stop valve

Press the  key to display the menu of the leakage protection's stop valve.

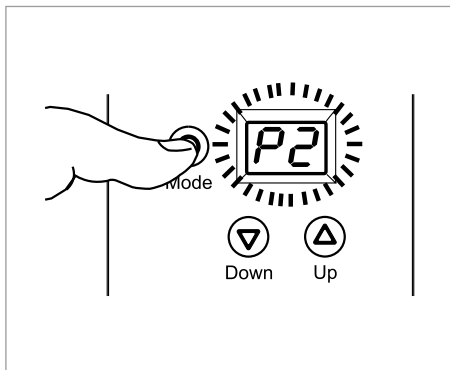

Press the  key to save the settings.



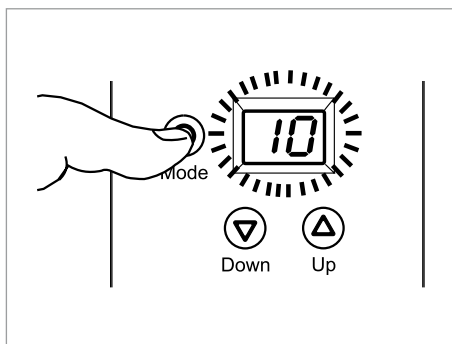

Press the  key again to display the current status of the leakage protection's stop valve.



5.8 Changing the stop valve's position

In order to change the stop valve's position, unlock the keyboard, if necessary.

Set the desired position by means of the  or  key.

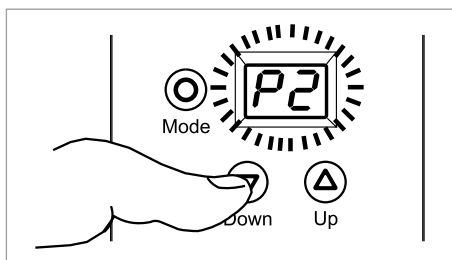

Information: When the SYR Safe-T has recognized a volume-based leakage, it closes the installation and opens it again after 30 seconds, in order to check whether more water is being drawn off.



If this is not the case, the Safe-T remains open and allows for more water to be drawn off up to the set volume.

5.9 Re-opening the stop valve after leakage

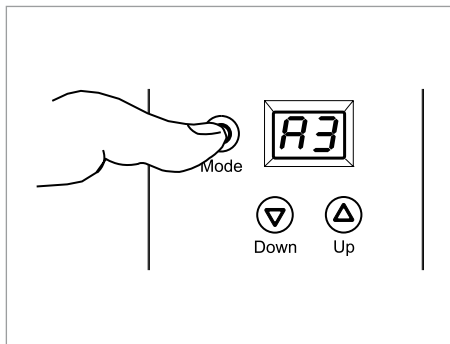
When the SYR Safe-T has isolated the installation after having recognized a leakage problem, it can be re-opened by pressing the  key.



6. Other settings

In order to get into the menu for other settings, press the  key and simultaneously three times the  key.

Unlock the keyboard (4.1, page 3) if necessary, prior to changing the values.

6.1 48 hours - anti-leakage system

In order to also ensure a sufficient leakage protection in case of a longer absence without having activated the vacation supervision, use the following function:

When no water is drawn off during 48 hours, the main stop valve isolates the system for 3 minutes.

When the stop valve opens again after 3 minutes, the device verifies whether water continues to flow.



If the flow of water exceeds 250 ml, a leakage problem is suspected → Message A8 is displayed.

The 48 hours anti-leakage system is deactivated in the standard setting.

6.2 Activating /deactivating the 48 h-anti-leakage system

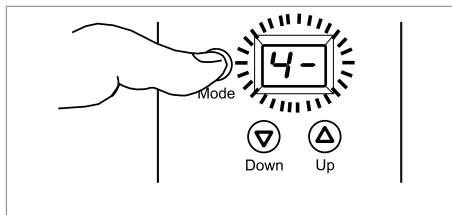
Indicate whether the 48 hours anti-leakage system shall be activated or deactivated.



Set the desired status by means of the  or  key and save the change with the  key.

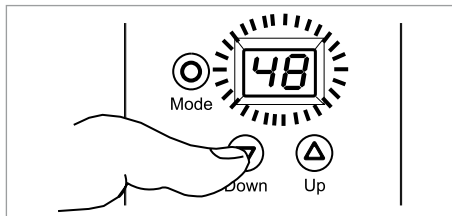

6.3 Time-based leakage (volume)

When the time-based leakage protection is activated, the time set for the standard leakage supervision is deactivated and replaced by this time-based protection.

The set volume is not taken into consideration.



Example: When selecting the 600 liters setting, a leakage problem would be suspected after 3 hours, even if the 600 liters volume has not been reached.

However, if the time-based leakage supervision is set to 8 hours, a leakage problem is only suspected after 8 hours.

In this case, the maximum flow rate shall not exceed 75 l (600 liters / 8 hours = 75 liters / h) → Message A9 is displayed.

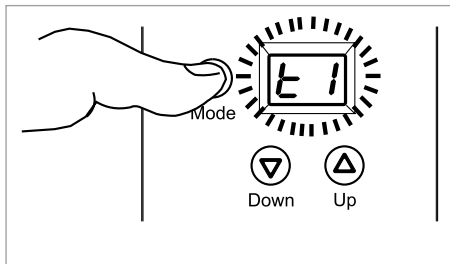
Press the  key until the menu of the time-based leakage (volume) is displayed.



Press the  key again and use the  or  key to adjust the number of hours after which the flow of water (1-9) has to be stopped, or to deactivate this function.

This setting is deactivated in the standard setting.

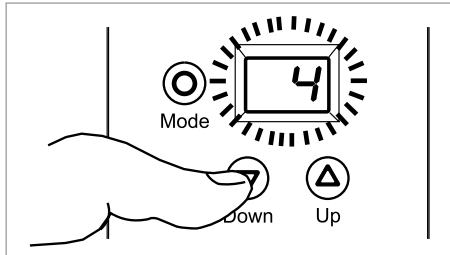

Save the change by pressing the  key.

6.4 Time-based leakage (flow rate)

If the flow rate exceeds 3500 l/h, a leakage problem is suspected → Message A4 is displayed.

The standard value of 1 minute can be changed with this parameter.



When the flow rate remains under 3500 l/h before the time has expired, the time is reset.

When the flow rate has been exceeded, the time starts again.

This parameter cannot be switched off or reset to „0“.

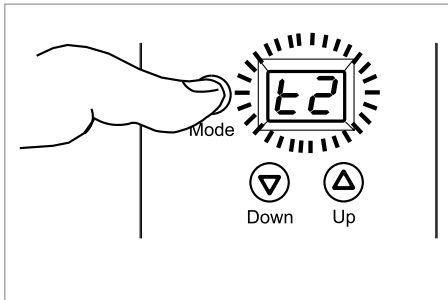
Press the  key until the time-based leakage (flow rate) menu is displayed.



Press the  key again and use the  or  key to set how long (number of minutes) the device shall wait before closing the water supply when the flow rate exceeds 3500 l/h.

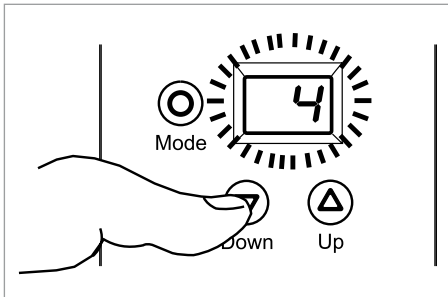



Save the change by pressing the  key.

6.5 Unlocking the device

The next step leads to the menu allowing to unlock the device.

When the SYR Safe-T has isolated the system after an unintended volume-based leakage, the device allows to determine whether it shall re-open after 30 seconds without water being drawn off.

Press the  or  key to activate or deactivate the function.

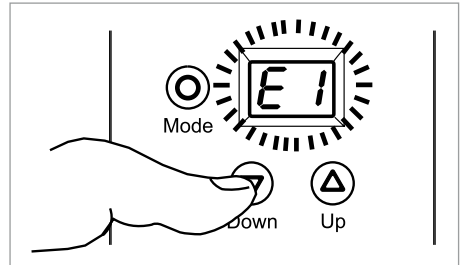





Press the  key to save the change.

6.6 External alarm contact

The menu offers settings for a potential free contact.

This contact offers various possibilities to display or signal an alarm.

Value	Meaning	Symbol
0-	Contact is deactivated	
01	Closing contact	
02	Opening contact	
03	Impulse contact	

Use the  or  key to set how the Safe-T's alarm contact is to be programmed.

Save the change by pressing the  key.

This function is only available in conjunction with the mains plug.

6.7 Buzzer

The menu Buzzer allows to select an acoustic signal in addition to the displayed message.

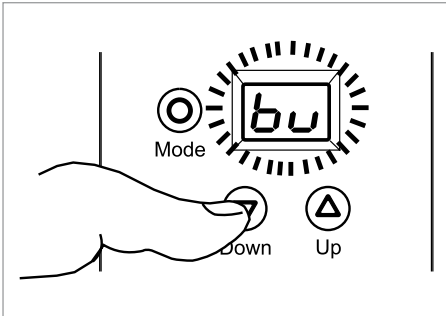

Set the desired status by means of the ∇ or \triangle key and save the change by pressing the \odot key.

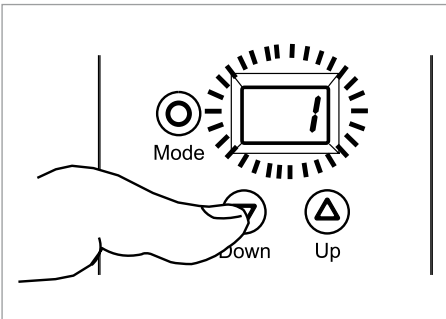

This function is only available in conjunction with the mains plug.

6.8 Contact 1

You can register a connected floor sensor in the Safe-T's menu contact 1.

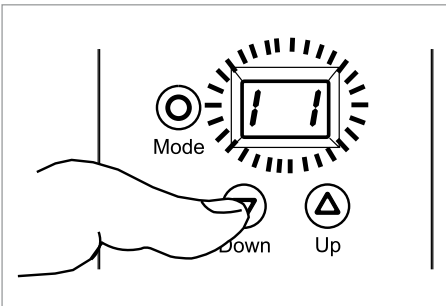

Caution: The plug has to be fully inserted into the socket!

Set the desired status by means of the ∇ or \triangle key and save the change by pressing the \odot key.

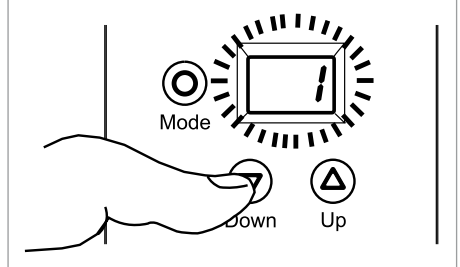

A plausibility test is carried out and a message is displayed after at least one minute.

6.9 Contact 2

The contact 2 offers many connection possibilities.

You can connect for instance floor sensors or temperature probes.

The Safe-T can also be actuated via switch-buttons, phone impulses, timers, radio-controlled floor sensors etc.

The system allows for the following settings:

Value	Meaning
--	Contact is deactivated

The positions 1 to 3 offer various contact possibilities able to isolate the installation.

With these settings, press the \odot key after a signal to unlock the device again.

Value	Meaning	Closed	Open
1	Impulse		\odot key
2	Opening contact		\odot key
3	Closing contact		\odot key

The positions 4 to 6 also offer various contact possibilities able to isolate the installation.

With these settings, the device waits for a signal from outside to unlock again.

Pressing the \odot key is not required as the opening process runs automatically once the signal is given.

Value	Meaning	Closed	Open
4	Impulse		
5	Opening contact		
6	Closing contact		

This function is only available in conjunction with the mains plug.

6.10 Mounting conditions

Finally, you can select whether the Safe-T shall supervise the installation with full (Hc) or restricted (only floor sensor) (Hd) supervision.

When selecting the restricted supervision, the leakage protection is only ensured by the floor sensor.

All other supervising functions are deactivated!

Example of installation in an apartment house:

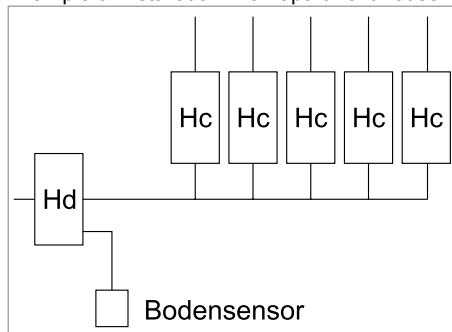

Press the ∇ or \triangle key to define the conditions.

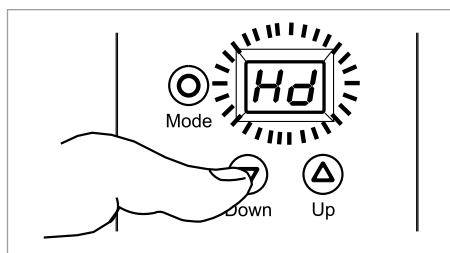

Save the change by pressing the \odot key.

7. System information

Press the \odot key and once the ∇ key at the same time in order to get into the menu for the system information.

Note: This level only allows reading data. They cannot be changed.

7.1 Serial number

The menu allowing to read the serial number is displayed.

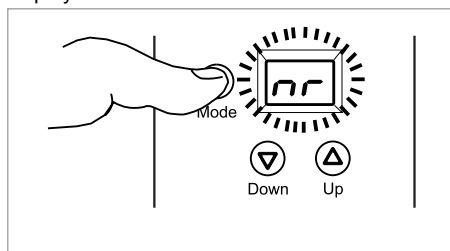

Press the \odot key to display the serial number.

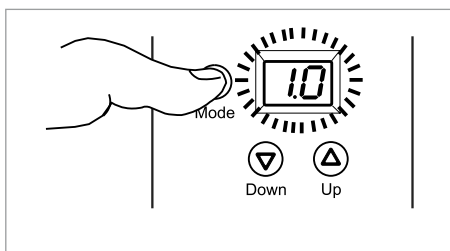

Press the \odot key to continue.

7.2 Battery power

The menu for the battery power is displayed.

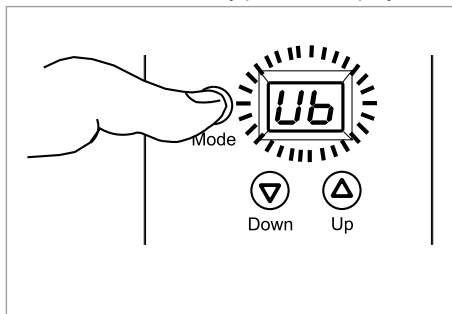

Press the  key to display the battery power.

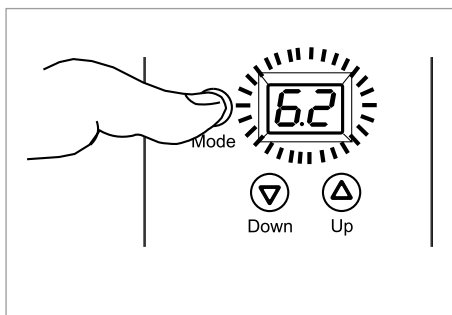

Press the  key to continue.

7.3 Alarm memory

The SYR Safe-T has 8 memory spaces designed to save alarm messages.

Press the  key several times to read these messages.

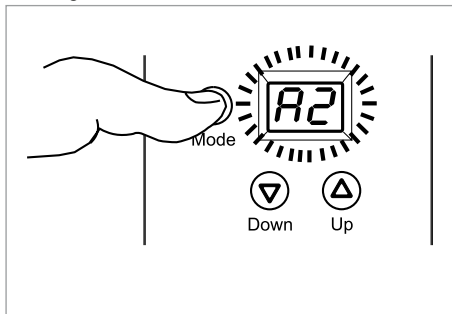

When no message has been saved yet, the following appears in the display:

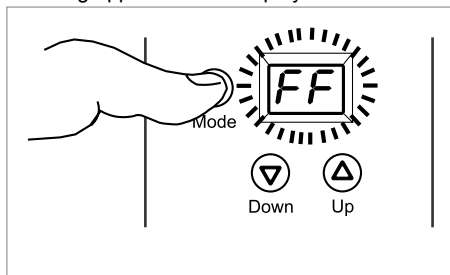

8. Emergency unlock function

The emergency unlock function is designed to unlock the system manually in case the SYR Safe-T isolates the installation and a power failure occurs at the same time.

The emergency unlock function is located on the back side of the leakage protection module.

Remove the two cover parts sideways.

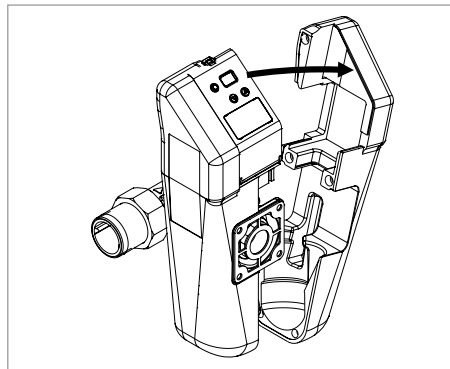

The key for the manual opening is located on the inner side of the left cover.

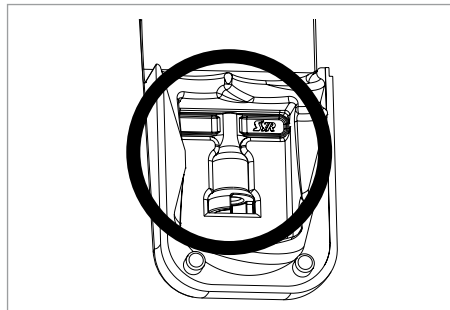

Remove the clamp from the control unit so that it can be lifted and taken off.

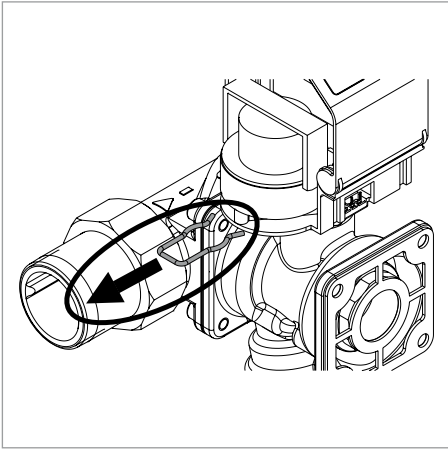

Put the key in the required position and turn it in the direction of the arrow until the water flows again.

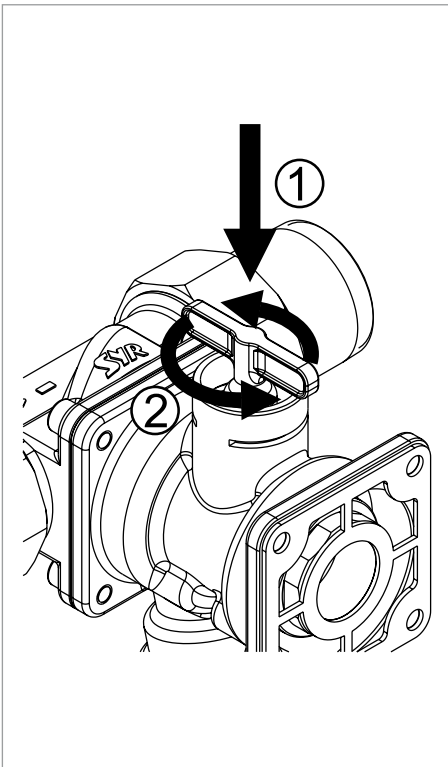

Remove the key and follow the instructions to restart the device (8.1, page 11).

Mount the control unit and secure it with the clamp.

Put the two insulating covers back into place.

8.1 Restart



Caution: Do not fit the control unit on the Safe-T to restart the system!

As the position has been changed manually with the emergency unlock function, the SYR Safe-T should be restarted.

Unlock the keyboard.

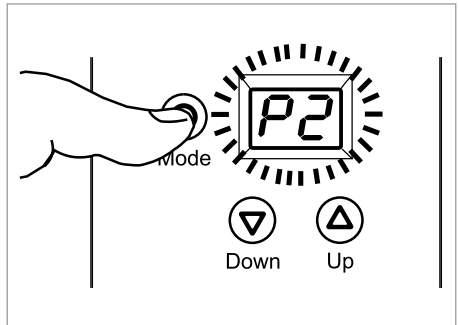
Press the  key until reaching the menu „AB“.



Press the  or  key to set the status „P1“.

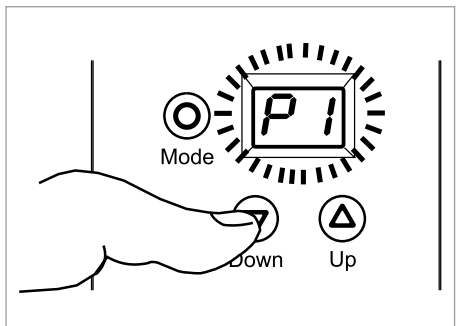

Press the  key to save the settings.

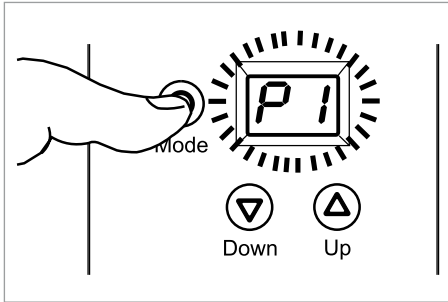

The device is now ready for operation.

9. Technical specifications

Service temperature:	max. 30°C
Ambient temperature:	10 - 60°C
Nominal pressure:	16 bar
Type of protection:	IP 21
Batteries:	4 x LR06
Power mains plug:	9V DC
Max. load of external potential free contact	
IN2:	min. 12V / 20mA
Out:	max. 24V / 2A

Flow rate:

	DN 20	DN 25	DN 32
Δp 0.2 bar	2.0 m³/h	2.3 m³/h	2.5 m³/h
Δp 0.5 bar	3.5 m³/h	3.8 m³/h	4.0 m³/h
Δp 1.0 bar	5.2 m³/h	5.7 m³/h	6.0 m³/h

10. Connections

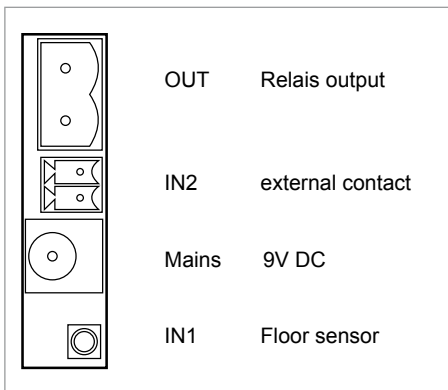

11. Accessories

Mains power adapter:	1100.00.900
Plug:	2320.00.901

More information available under

export@syr.de

Only qualified installers are authorised to install and service the device. Do not clean synthetic parts with solvent-based detergents. Protect the device and the electronic system against frost. When submitted to hard shocks, the synthetic part concerned shall be exchanged (even when no damages are visible). Avoid strong water hammers caused for instance by downstream solenoid valves (danger of burst).





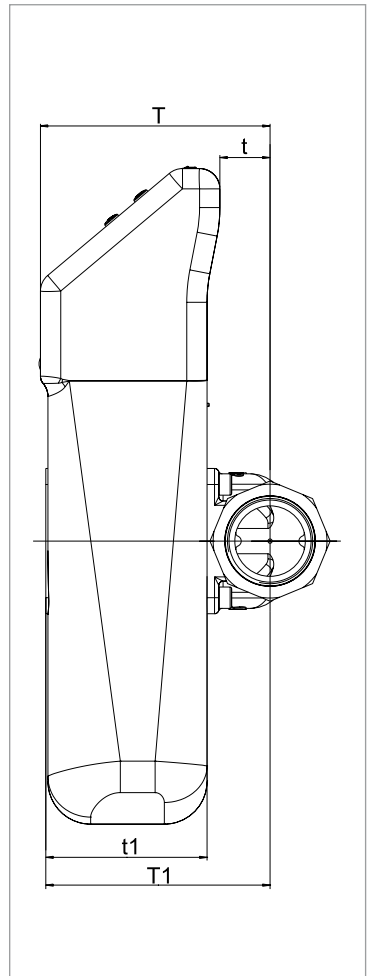
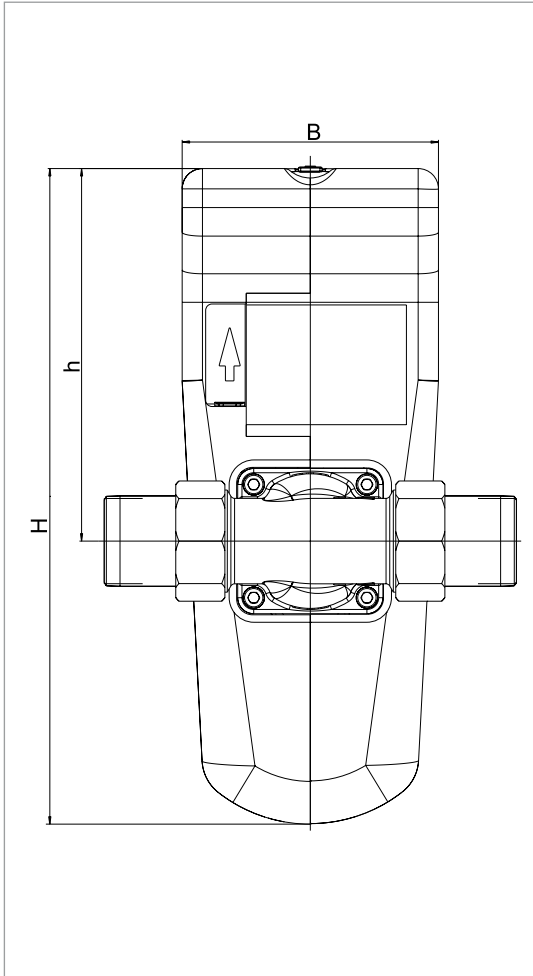



The packaging serves as transport protection. Should it be severely damaged, do not install the device!

12. Dimensions



Type		SYR Safe-T Leakage protection module
Nominal size		DN 20 - 32
Dimensions	T	108 (mm)
	t	24 (mm)
	T1	105 (mm)
	t1	76 (mm)
	H	307 (mm)
	h	174 (mm)
	B	120 (mm)

13. Messages

Display	Cause	Solution
A1	<ul style="list-style-type: none"> - The stop valve cannot be operated. Probably caused by dirt. - Defective motor. 	<ul style="list-style-type: none"> - Press the  key. The system tries again to reach the position. - Contact your local dealer.
A2	<ul style="list-style-type: none"> - The turbine is blocked. 	<ul style="list-style-type: none"> - Contact your local dealer.
A3	<ul style="list-style-type: none"> - A volume-based leakage problem has been identified. The set or admissible volume flow has been exceeded. 	<ul style="list-style-type: none"> - Press the  key to open the stop valve. Adjust the protection level and eliminate the leakage problem.
A4	<ul style="list-style-type: none"> - A continuous volume flow > 3500l/h within one minute has been identified (for instance burst pipes). 	<ul style="list-style-type: none"> - Press the  key to open the stop valve. Adjust the protection level and eliminate the leakage problem.
A5	<ul style="list-style-type: none"> - The system has identified a vacation leakage problem. The set or admissible volume flow has been exceeded. 	<ul style="list-style-type: none"> - Press the  key to open the stop valve and eliminate the leakage problem.
A6	<ul style="list-style-type: none"> - The system has identified a leakage problem at contact IN1 (floor sensor). 	<ul style="list-style-type: none"> - Press the  key to open the stop valve and eliminate the leakage problem.
A7	<ul style="list-style-type: none"> - The system has identified a leakage problem at contact IN2. 	<ul style="list-style-type: none"> - Press the  key to open the stop valve and eliminate the leakage problem.
A8	<ul style="list-style-type: none"> - A 48h - leakage problem (for instance toilet flush) has been identified. 	<ul style="list-style-type: none"> - Press the  key to open the stop valve and eliminate the leakage problem.
A9	<ul style="list-style-type: none"> - The flow rate time criterion has been exceeded. The set or admissible flow time has been exceeded. 	<ul style="list-style-type: none"> - Press the  key to open the stop valve and eliminate the leakage problem.
bA	<ul style="list-style-type: none"> - The batteries are empty. 	<ul style="list-style-type: none"> - Replace the batteries (4 x LR06).