

Reliance Valves Multisafe™ Floor Leak Sensor

A smart leak detection system offering a new level of protection from costly water damage.

Overview

The Reliance Valves Floor Leak Sensor is placed in areas where intensive monitoring is required such as under baths, utility rooms, communal facilities or IT data rooms. When the smart sensor detects water on the floor, room temperatures that are too low, or excessive levels of humidity, an LED will flash and a loud warning signal is given. If the floor sensor is connected to Wi-Fi, an alert will also be sent by email or text message. All of the functions of the Floor Leak Sensor can be viewed and adjusted in the free user-friendly app.

When combined with the Reliance Valves MultiSafe™ Leak Detector Control Valve, if a leak is detected a signal will automatically be sent to the valve to shut the water off.

Features and benefits

- Intensive monitoring of moisture and temperature levels in critical areas.
- Standalone system with onboard alarm
- Connect to WiFi for instant alerts by email or text message
- Settings can be adjusted to suit individual requirements
- Monitor and change settings via a free user-friendly app
- Monitors battery level and sends an alert when it reaches 20%
- Automatically isolates water supply when connected to the MultiSafe Leak Detector Control Valve

Product code	Description
LEKP100050	MultiSafe™ Floor Leak Sensor



Reliance Valves Multisafe™ Floor Leak Sensor

Working parameters & specifications

Operating temperature	-20 to 50°C
Humidity settings	0 – 95%
Protection class	IPX4
Batteries	2 x 1.5V AA

Materials

Body	ABS plastic
Seals	EPDM rubber
Metal parts	Stainless steel

Dimensions – All measurements in mm unless otherwise stated

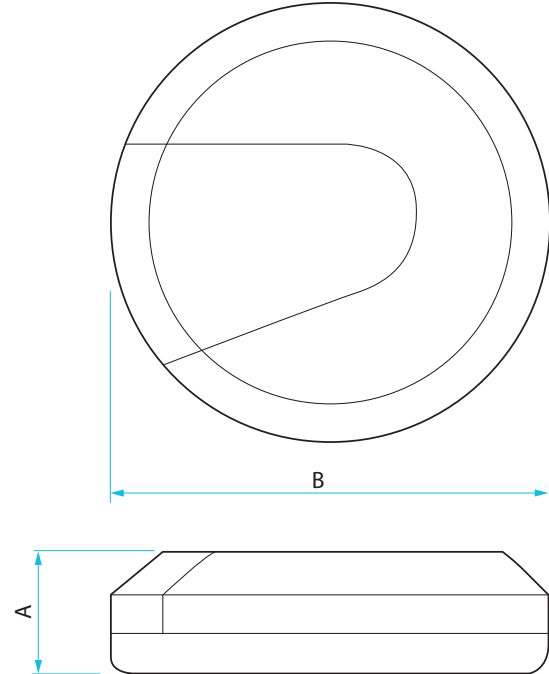

Product code	A	B
LEKP100050	32	80