

Working Parameters and Specifications

Temperature setting range:	35-60°C
Flow supply temperature:	90°C max
Return supply temperature:	5-75°C
Temperature stability:	+/- 2°C
Working pressure, static:	10 bar max
Working pressure, dynamic:	6 bar max 0.2 bar min

Materials

Body:	Cast gunmetal, nickel plated
Internal components:	DZR brass
Seals:	Nitrile elastomer
Spring:	Stainless steel
Piston:	Polysulfone polymer
Fittings:	DZR brass

Flow Characteristics

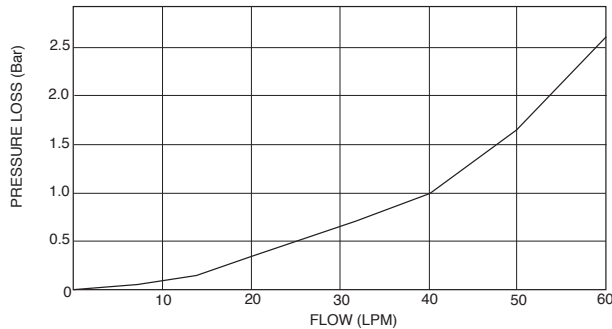

Dimensions

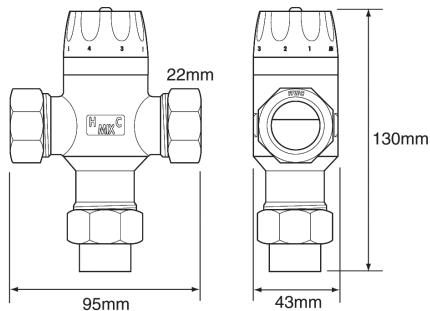

Reliance Worldwide Corporation
(UK) Ltd
Worcester Road,
Evesham,
Worcester,
WR11 4RA,
UK

Tel: +44 (0)1386 712 400
Fax: +44 (0)1895 712 401

www.rwc.co.uk

Installation and Maintenance
Instructions

RELIANCE
WATER CONTROLS

Heatguard UFH
Blending Valve 22mm



Reliance Worldwide Corporation (UK) Ltd reserves the right to make changes to the product which may affect the accuracy of information contained in this leaflet.
ZINS219061_003_10-15

A 22mm underfloor heating blending valve for mixing the flow and return water to achieve a stable system temperature in underfloor heating systems.

Reliance Worldwide Corporation (UK) Ltd.

Reliance Worldwide Corporation (UK) Ltd are part of the Australian based group of companies collectively known as Reliance Worldwide Corporation, with the UK brand known as Reliance Water Controls.

Reliance Worldwide Corporation (UK) Ltd is a specialist in the design, distribution and technical support for temperature and flow controls.

With group offices and manufacturing plants throughout the world RWC offers a wealth of knowledge and expertise which is reflected throughout our products. Being part of many specialised trade associations and having our own UKAS accredited laboratory, makes us at the forefront of any new regulations or changes which impact the industry, and allows for continuous product development and innovation, within our specialised product area.

Description

A 22mm Heatguard UFH blending valve for mixing the flow and return water to achieve a stable system temperature in underfloor heating systems.

The UFH blending valve contains temperature sensitive components. Soldering near the valve body must be avoided.

Installation and Commissioning

Ensure that the valve is properly connected to the pipework and that the flow from the boiler is connected to the hot inlet and the return is connected to the cold inlet, the flow for the loops or manifold is connected to the mixed water outlet connection.

The valve may be installed in any orientation, provided the connections are fitted, as stated above.

Please ensure that the commissioning of the valve is done under normal operating conditions. The Heatguard UFH blending valve is supplied factory set at 43°C. To alter this setting proceed as follows:

1. Remove the screw which secures the cap by using the allen key provided then lift the cap off (Fig 1).

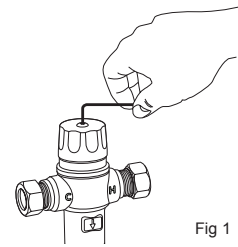

2. With both the hot and cold supplies turned fully on and the terminal fitting open, adjust the temperature to the required setting, by using the cap to turn the adjustment spindle.

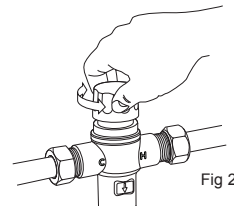

3. Turn the cap clockwise to decrease or anti-clockwise to increase the temperature (Fig 2).

4. A digital hand-held thermometer should be used to measure the outlet temperature correctly.

5. Once the correct temperature has been set re-fit the cap, ensuring it is secured through the slots on the locking ring so that the valve cannot be adjusted by the end user. (Fig 3)

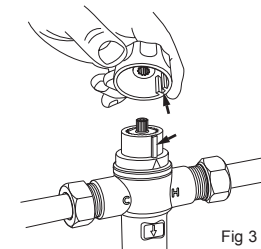

Maintenance

The performance of the Heatguard UFH blending valve should be checked on an annual basis and verified against the original installation performance. If the water or installation conditions are more severe this check should be carried out more frequently.

If water conditions or installation conditions are severe and the valve is sluggish in operation, it is possible that there is a build up of scale or debris within the valve, it can then be stripped down and cleaned very easily:

1. Isolate the hot flow and cold return supplies and remove the valve from the installation. Make note of the orientation of the parts as they are removed so that they can be re-assembled in the correct manner.

2. To clean the internals of the main valve body, first remove the cap using an allen key, then remove the plastic locking ring, then finally carefully remove the valve headwork by unscrewing the large hex nut.

3. Slide the piston and thermostat assembly out of the valve body and clean all internal surfaces and 'O' rings with clean running water.

4. Using a WRAS approved silicone based waterproof grease, lightly lubricate the 'O' ring in the body and the external surface of the piston.

5. After cleaning, re-assemble the Heatguard UFH blending valve. Re-set and test the valve as laid out in the commissioning section.

Typical Installation

