

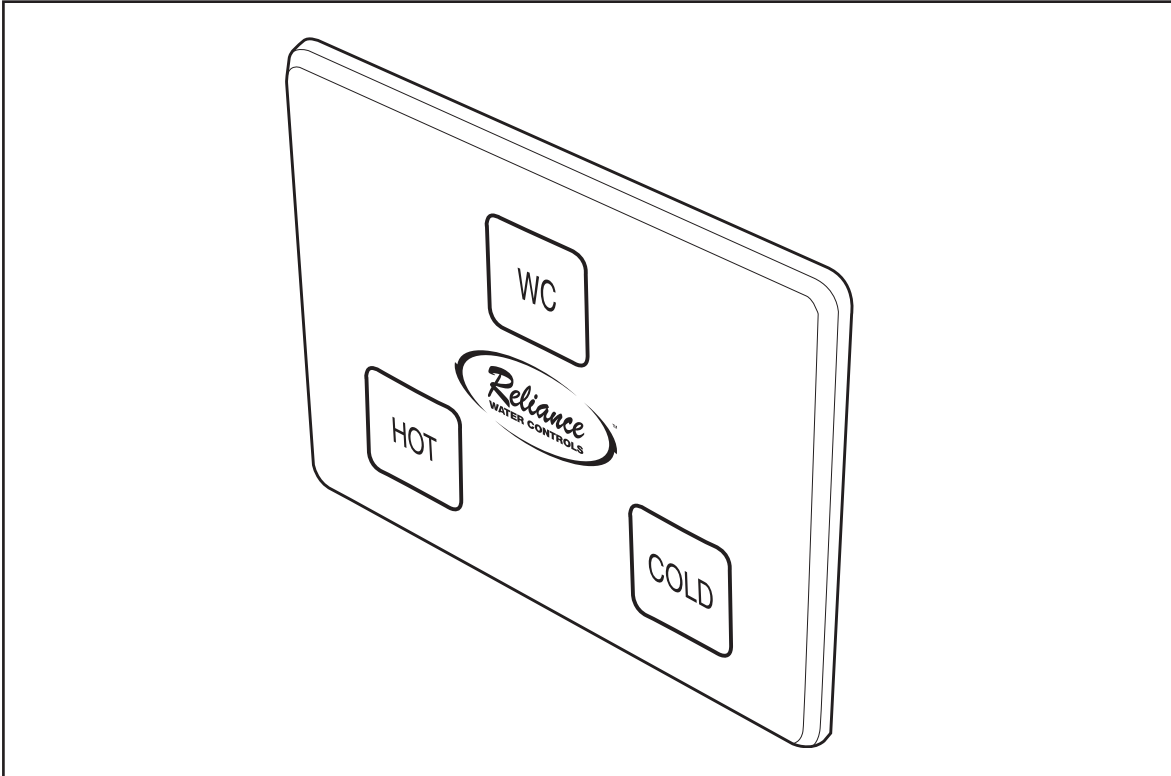

## Product Specification Sheet

### Senselec® TS 3 Switch Keypad



3 switch keypad for use with the Senselec controllers and solenoid valves.

#### Product Features and Benefits

- **Tough and durable** 3 switch keypad for use with the Senselec TS control system.
- **Anodized aluminium housing with laser etched characters** to indicate the touch sensitive zones.
- **Low profile construction with no ligature points.**
- **One shot actuation** tested to 500,000 operations for complete quality assurance.
- Piezoelectric technology means that there is no voltage present in the switch giving **complete system safety.**
- Comes as a complete unit for **easy and fast installation** in either solid wall or panel mount installations.

# Senselec® TS 3 Switch Keypad

## Description

The Senselec 3 switch keypad is a purpose built anti vandal keypad designed specifically for secure environments. They are piezoelectric actuated devices. When pressure to a force of 3-5N TYP is applied to the indicated areas, a 'burst' of energy is sent to a control unit; this is a signal to the controller that tells it to open a solenoid valve for a specific length of time.

The 3 switch keypad is part of the integrated Senselec system and must only be used with the Senselec controllers and solenoid valves.

Maximum wall thickness for the cross wall version is 150mm and for the panel mount version is 50mm.

## Product Range

|              |  |
|--------------|--|
| SENS 600 001 | Senselec TS 3 Switch keypad through wall 1-150mm |
| SENS 600 003 | Senselec TS 3 Switch keypad panel mount 1-50mm   |

## Specifications

|                    |                      |
|--------------------|----------------------|
| Activation:        | 3-5N TYP             |
| Switch action:     | One shot 120mSec TYP |
| Protection system: | IP 68                |

## Dimensions

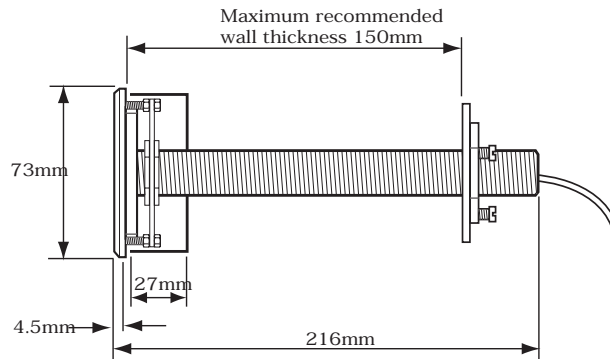

## How to Specify

A piezoelectric 3 switch keypad in anodized aluminium for use in secure environments (include correct product range code).

## Guarantee

All Reliance® products undergo strict performance tests prior to despatch, and are guaranteed against faulty materials and workmanship for one year from date of purchase. This is in addition to any statutory rights.

| Contacts:  | Sales Enquiries    | Technical Support   |
|------------|--------------------|---------------------|
| Telephone: | +44 (0)1386 712400 | +44 (0)1386 47148   |
| Fax:       | +44 (0)1386 47028  | +44 (0)1386 422217  |
| E-Mail:    | sales@rwc.co.uk    | technical@rwc.co.uk |



**Reliance Water Controls®**  
Worcester Road, Evesham, Worcestershire, WR11 4RA, UK  
Tel: +44 (0)1386 47148 Fax: +44 (0)1386 47028 www.rwc.co.uk

