

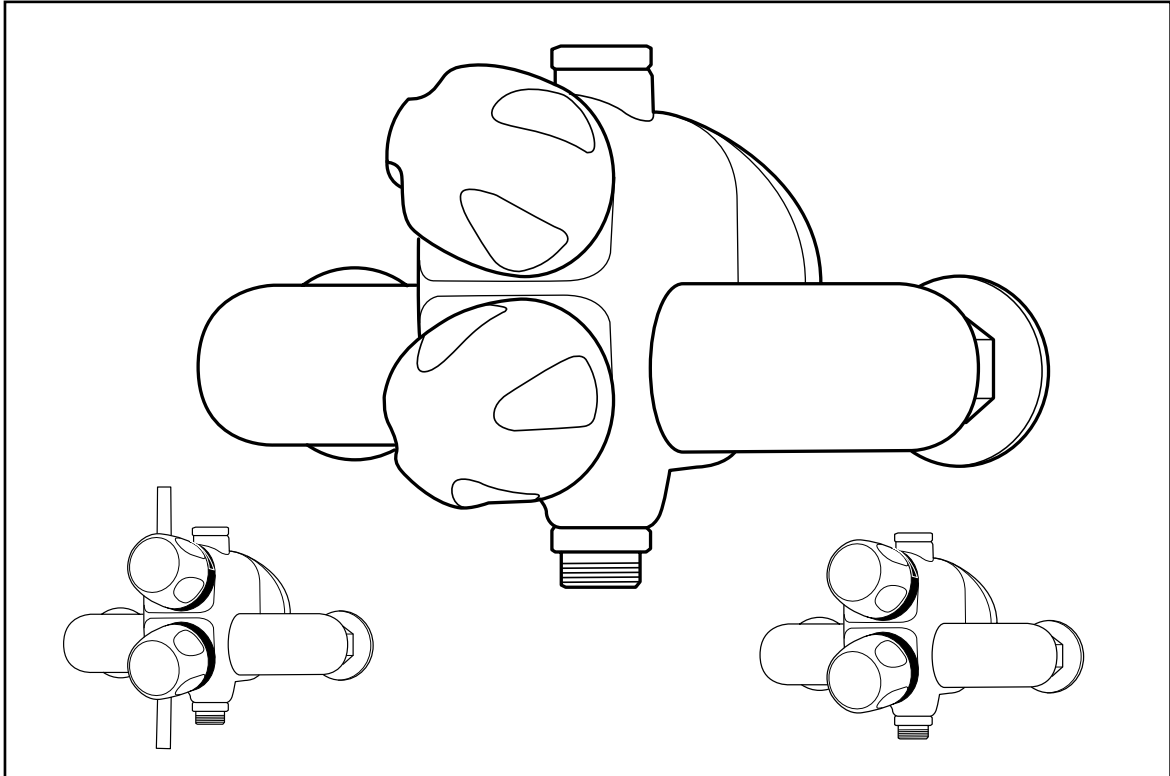

Product Specification Sheet

Heatguard DC150 Shower Valve



Ultra modern, streamlined shower with dual control has specially designed large internal flow paths to give excellent flow rates at low pressures.

Product Features and Benefits

- **Unique, easy to use separate controls** unlike conventional ring within ring design.
- **Single piece** thermostatic cartridge maintains **excellent temperature control** whilst **simplifying maintenance** thus reducing downtime.
- **Good flow rates** even at **low pressures** (10 lpm at 0.1 bar).
- **Push-fit connections** make for easy installation **reducing site time**.
- **Rotational elbows** with a choice of top, bottom or rear inlets gives **freedom of installation**.
- 120° **ceramic disc** flow control for **easy operation**.
- **Lever handle** option available, which allows easier operation by disabled or elderly users.
- Top or bottom outlets can be changed on site for complete **flexibility of installation**.

Heatguard DC150 Shower Valve

Description

The Heatguard DC150 is a shower valve of contemporary style with unique, easy to use separate controls which allows more accurate temperature selection. The specially designed large internal flow paths give greater flow even at low pressures. A range of body colours with three different handle styles gives the customer a wide choice of variations which will suit all those selecting a contemporary style shower valve.

Push fit connections and a choice of either top or bottom outlets gives freedom of design and installation. The outlet fitting itself is removable and reversible so that either compression or flat faced fittings can be used. Large surface area serviceable strainers and one piece Heatguard thermostatic cartridge system and flow control cartridge ensures servicing is quick and easy.

Product Range

THRM 150 002:	Heatguard DC150 chrome body, chrome fluted handles
THRM 150 011:	Heatguard DC150 Contemporary chrome body, chrome handles
THRM 150 021:	Heatguard DC150 Lever chrome body, chrome handles

Materials

Body:	Cast brass
Inlet strainers:	Stainless Steel
Cartridge:	Brass CW 614 N
Seals:	NBR
Piston coating:	PTFE
Protective coatings:	Chrome

Dimensions

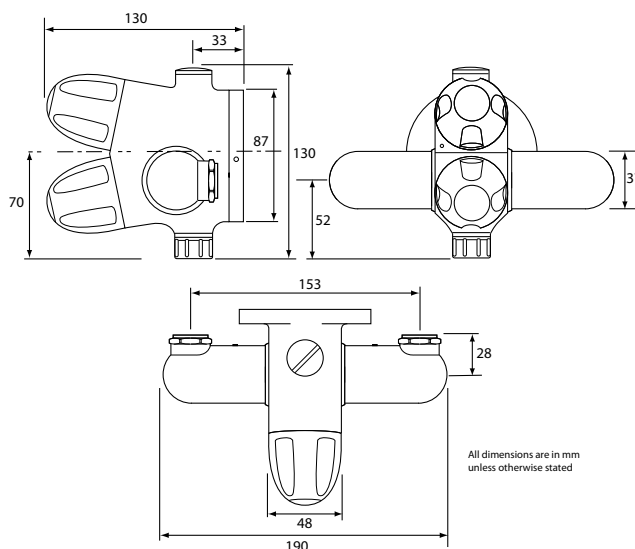

Specifications

Minimum Pressure:	0.2 bar
Maximum pressure:	5.0 bar
Static test pressure:	10 bar
Max. pressure loss ratio:	5:1
Max. hot water temperature:	85°C
Min. hot/blend temp. differential:	10°C

How to Specify

Contemporary styled thermostatic mixing shower valve with separate flow and temperature control handles and a choice of either a top or bottom outlet port. The outlet fitting itself must be removable and reversible so that either compression or flat faced fittings can be used. (Include correct product range code).

Guarantee

All Reliance® products undergo strict performance tests prior to despatch, and are guaranteed against faulty materials and workmanship for one year from date of purchase. This is in addition to any statutory rights.



Reliance Water Controls®
Worcester Road, Evesham, Worcestershire, WR11 4RA, UK
Tel: +44 (0)1386 712400 Fax: +44 (0)1386 712401 www.rwc.co.uk

