

Floguard Single Check Valves

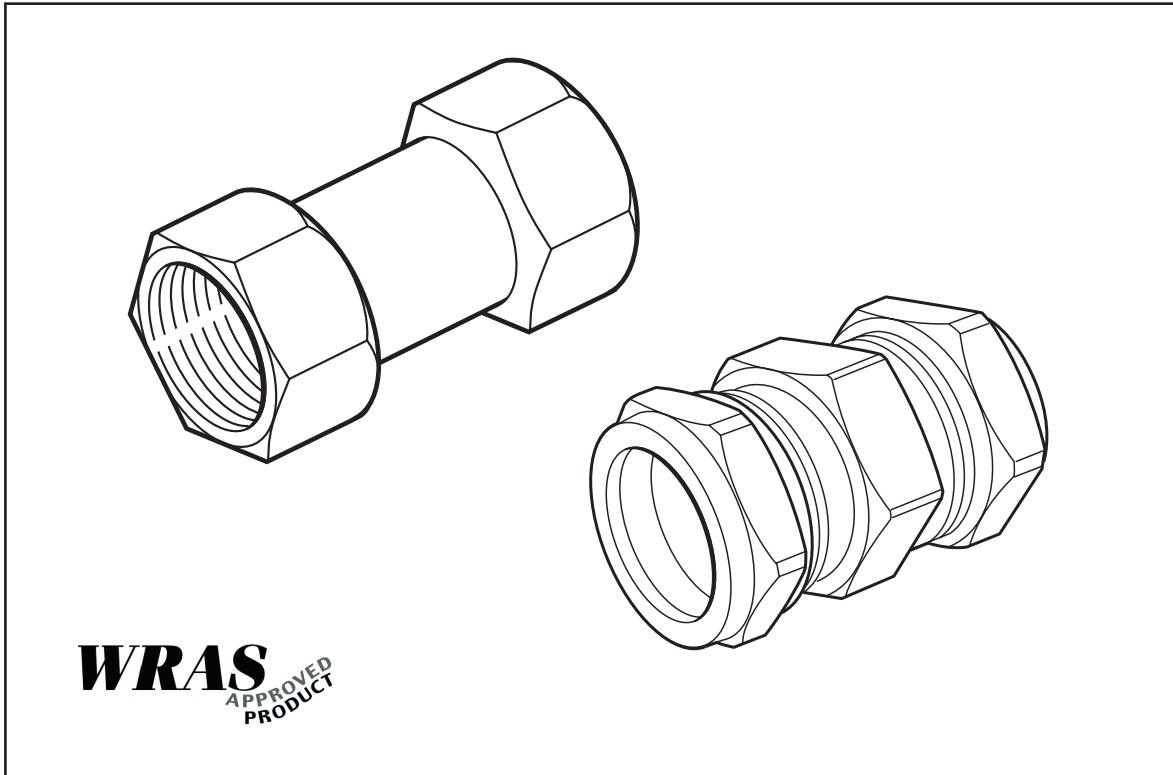

Lightweight, DZR brass single check valves for Class 2 contamination risks.

Product Features and Benefits

- Single check valves protect against the risk of back-flow and back-syphonage contaminations.
- Compact lightweight construction for easy installation.
- Minimum pressure drop giving good flow rates.
- Ideal for all Class 2 contamination risks as per Water Supply (water fittings) Regulations 1999.
- Available with a comprehensive selection of FBSP and compression connections.

- ✓ WRAS Approved
- ✓ Conform to BS 6282 Part1

Floguard Single Check Valves

Description

Manufactured from DZR brass the WRAS approved Floguard Single Check Valve is used for the prevention of back-flow and back-syphonage contamination risks in accordance with the Water Supply (water fitting) Regulations 1999.

Product Range

FLOW 235 001:	15mm Floguard SCV
FLOW 235 002:	22mm Floguard SCV
FLOW 235 003:	28mm Floguard SCV
FLOW 235 004:	1/2" FBSP Floguard SCV
FLOW 235 005:	3/4" FBSP Floguard SCV
FLOW 235 006:	1" FBSP Floguard SCV
FLOW 235 007:	1.1/4" FBSP Floguard SCV
FLOW 235 008:	1.1/2" FBSP Floguard SCV
FLOW 235 009:	2" FBSP Floguard SCV

Materials

Body:	DZR Brass
Seals:	NBR Elastomer
Check Cartridges:	Acetyl Copolymer
Spring:	Stainless Steel

Standards

Conforms to BS 6282 Part 1

Approvals

WRAS Approval Number: 1001322

Dimensions

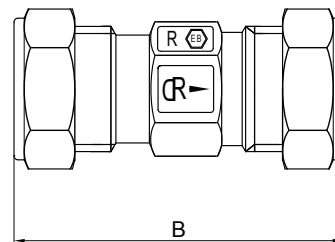
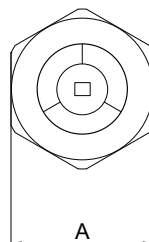

Product Code	Connection	A	B
FLOW 235 001	15mm	24	57
FLOW 235 002	22mm	32	63
FLOW 235 003	28mm	38	71

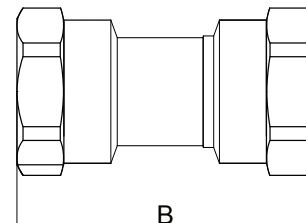
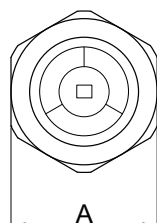

Product Code	Connection	A	B
FLOW 235 004	1/2" FBSP	25	51
FLOW 235 005	3/4" FBSP	31	60
FLOW 235 006	1" FBSP	38	67
FLOW 235 007	1 1/4" FBSP	46	76
FLOW 235 008	1 1/2" FBSP	52	83
FLOW 235 009	2" FBSP	65	103

Specifications

Test Pressure:	16 bar
Working pressures:	0.1 bar min. 10 bar max.
Maximum temperature:	85°C

How to Specify

Single Check Valve supplied in DZR Brass suitable for all Class 2 contamination risks with FBSP or compression style connections (include correct product range code).



Reliance Water Controls®
Worcester Road, Evesham, Worcestershire, WR11 4RA, UK
Tel: +44 (0)1386 712400 Fax: +44 (0)1386 712401 www.rwc.co.uk

